

# Master Training Program on Water (Water Supply, In-house Processing, End-of-Pipe) in Textile and Garment factories

Promotion of Sustainability in the Textile and Garment Industry in Asia - FABRIC

Day 4: Presentation 3

# Water conservation – Low hanging fruits

**Mohammad Abbas Uddin Shiyak**, PhD, CText FTI  
Assistant Professor and Head  
Department of Dyes and Chemical Engineering  
Bangladesh University of Textiles

**Md Anwarul Islam**, MSc  
Consultant, Reed Consultancy

**After the completion of this module the learners will be able to**



- distinguish between different basic approaches in water conservation
- apply general good housekeeping principles and other basic/small measures
- implement up to medium cost and implementable measures with the help of consultants



Reference from WETI and  
FABRIC

**Any water conservation/minimisation measures require an adequate water management plan which is, together with water audits, part of the environmental management system (EMS). It includes:**

- flow diagrams and a water mass balance as a result of proper water consumption monitoring
- establishment of water efficiency objectives and development of actions to achieve them
- implementation of water optimisation techniques

Water audits should be carried out at least annually to establish the baseline and to set the target for next few years.



# Water conservation - Benefits

- Reduction in processing cost
- Reduction in wastewater treatment cost
- Reduction in thermal energy consumption
- Reduction in electrical energy consumption
- Reduction in pollutants load

# Training and Awareness – sample sheet

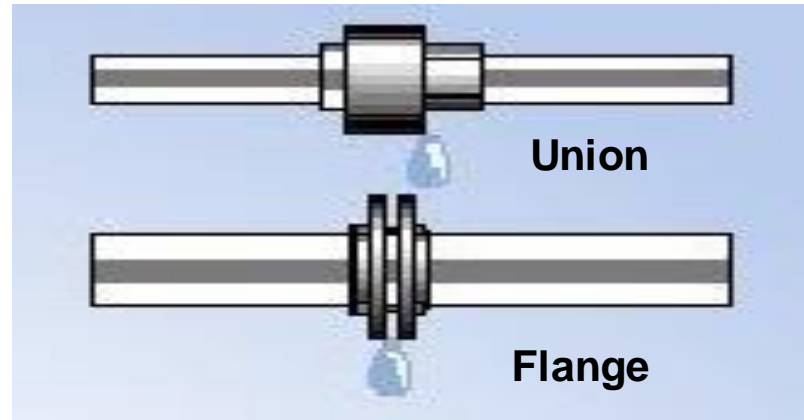

Water Loss	One drop/second
Hourly loss	0.5 litres
Annual loss	5 m <sup>3</sup>
Min. Annual water only cost	BDT 75

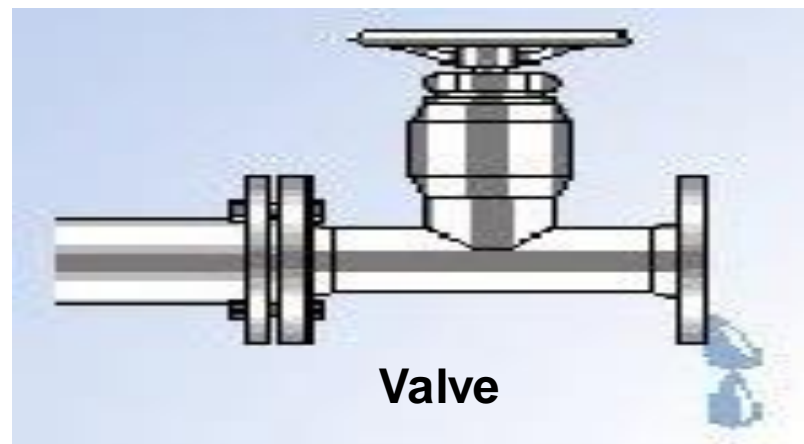

Water Loss	0.1 litres/minute
Hourly loss	6 litres
Annual loss	53 m <sup>3</sup>
Min. Annual water only cost	BDT 795

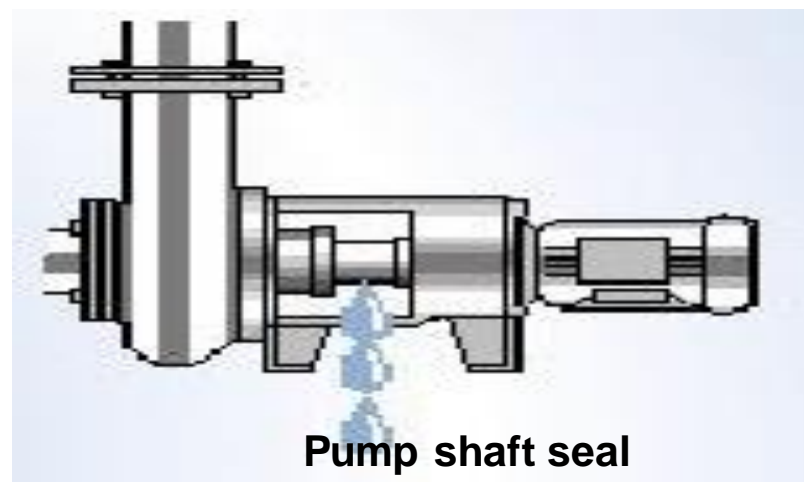

Water Loss	0 - 4 litres/minute
Hourly loss	0 - 240 litres
Annual loss	0 - 2100 m <sup>3</sup>
Min. Annual water only cost	BDT 31,500

# Internal audit/assessment and water balance data analysis



## Approach to Water Audit / assessment

1. Starts with Training and Awareness
2. Inculcating water saving thoughts within the employees
3. Establishment of Water Balance within the premises
4. Application of 3R's principle – Reduce, Reuse and Recycle
5. Monitoring & Reporting to Sustain the Benefits

# Water conservation

## Water Mass Balance

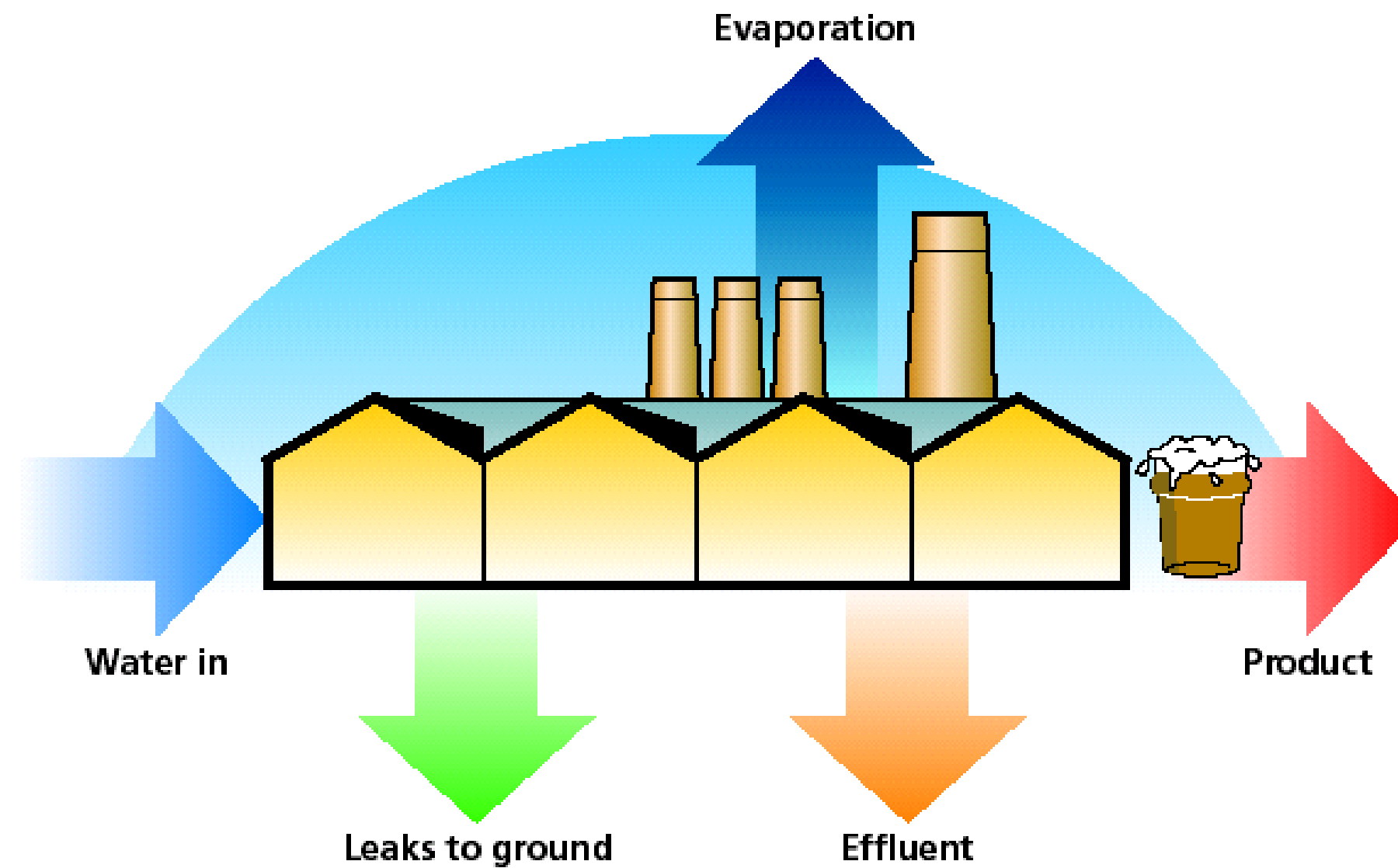

# Common good practices

# Common good practices

## Water Audit in building

### On-site survey and assessment of

- Water using hardware, fixtures, equipment, landscaping
- To develop recommendations for improving water use efficiency

### Typical Water Consumption Pattern in Building

- Cooling tower 30%
- Leakages 25%
- Domestic 40%
- Others 5% -(Irrigation & landscaping /Vehicle cleaning)

# Common good practices

## Housekeeping practices

### Up to 10-30% saving can be accomplished

- Eliminate water leaks
- Improve hose-pipe use
- Improve boiler blow-down practices
- Reuse of cooling water from different sources
- Reuse of cooling water from dyeing machines
- Reuse of condensate
- Installation of automatic water shut off valves at rotary and flatbed printing machines' blanket washing water
- Water savings from maintaining steam traps and system
- Insulate equipment and tanks
- Improve efficiency and consistency in bulk chemical preparation



## Eliminate water leaks

- Individual leaks can be responsible for a surprisingly significant loss of resources over the course of a year.
- A study estimates conservatively that leaks of water are responsible for up to 0.2 to 0.34 percent of water use at two of the visited factories.
- Eliminating leaks can thus mean savings of water ranging between approximately one-third of a ton of water per ton of fabric produced.
- Eliminating leaks consists of routinely investigating sources of water leaks, and implementing an effective preventive maintenance programme, requires virtually no investment costs and thus delivers instant payback.



# Common good practices

## Improve hose-pipe use

- Water is wasted too often when hoses or cooling water are left running
  - ✓ even after machinery is shut down,
  - ✓ after cleaning is completed, and/or
  - ✓ while cleaning is in progress.
- Low-flow and shut-off valves or trigger guns should be installed on hoses, and thermally-controlled shut-off valves can be installed on process units.
- Using a trigger gun or shut-off valves is cheap (US \$12 per trigger gun) and pays back within two months at the most.



# Common good practices

## Electronic wash system

### Electronic hand wash

- Saves up to 70% water in handwash

### Foam spray taps

- Saves up to 40% water in handwash





# Common good practices

## Improve boiler blow-down practices

- When steam is generated, dissolved solids and particles in the water are left behind and eventually build up to levels that make boiler operation increasingly inefficient.
- Boiler blow-downs (water bleed-off) shut the boiler down and remove water from the boiler to remove the accumulated particles.
- If more blowdowns than required are carried out, it means that extra water is consumed and heat is lost.
- If fewer blowdowns than necessary are carried out, this can result in the formation of scale in the boiler, higher energy consumption and reduction in the working life of the boiler.
- Factory should optimize blow-down frequencies by relying on measurements of total dissolved solids (TDS) in the boiler.



Gas boiler. Copyright: Kazi Farhan Hossain Purba

# Common good practices

## Uses of Recycled Water

### LOW END APPLICATIONS

- Toilet flushing
- Gardening
- Floor washing

### HIGH END APPLICATIONS

- Boiler feed
- Cooling water make-up
- Process water



Toilet flushing of ETP water. Copyright: Mohammad Abbas Uddin

# Common good practices

## Reuse of Cooling Water from Different Sources

**There are many sources in the textile industry where cooling water is used and wasted into the drain. These sources are as under:**

- Coal based boiler induced fan
- Coal feeding gate of steam boilers/therm oil heaters
- Thermosole padder's hydraulic pump
- Therm oil pumps at therm oil heaters
- Ager therm oil pump
- Calender cooling water
- Comfort cooling water
- Gas based therm oil pump cooling water
- Waterjet weaving loom

This water is in the range of 100 – 160 m<sup>3</sup>/ (collected and reused)



Photo: WETI Project

# Common good practices

## Reuse cooling water from dyeing machines

After completion of the dyeing process of the knitted polyester fabric, the temperature of the dye bath is reduced from 130°C to about 80°C by circulating the hot bath through heat exchanger

Fresh water is circulated in the heat exchanger to cool down the hot bath. The hot dye bath transfers its heat to the fresh water which gets warm

This continuous warm cooling water stream (50 - 60°C) from the heat exchanger is wasted in the drain

The quantity of this water is in the range of 57 to 179 m<sup>3</sup>/d which can be collected and reused in the process



Storage tank for hot water, cooling water. Copyright: Mohammad Abbas Uddin

# Common good practices

## Reuse of condensate

Condensate water includes water from heat exchangers in dyeing machines, drying ranges, and cooling cans on continuous ranges.

Traditionally, jet dyeing machines are equipped with common heat exchangers that are used for both heating and cooling, which is normally drained with other effluent and thus increases freshwater consumption as well as effluent quantity and load at effluent treatment plant.



Condensate Recovery system. Copyright: Mohammad Abbas Uddin

# Common good practices

## Installation of Automatic Water Shut Off Valves at Rotary and Flatbed Printing Machines' Blanket Washing Water

The printer table blanket is washed with forced water jets by means of two or three rows of multiple nozzles to remove the stains adhered to the blanket during printing operation

Generally, the blanket washing water at the printing machines is kept on running and wasted during machine stoppage (due to maintenance or change over)

The water saving is in the range of 50 to 90 m<sup>3</sup>/d

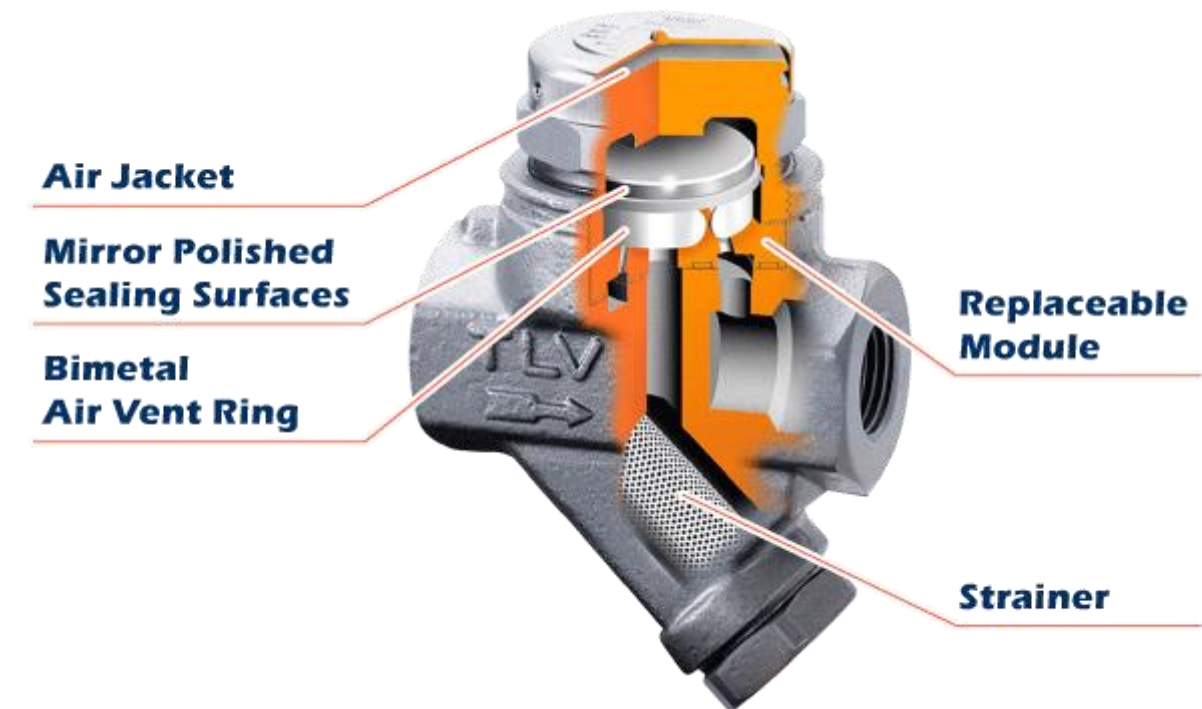

Photo: WETI Project

# Common good practices

## Water savings from maintaining steam traps and system

- The small leaks and inefficiencies in the steam systems across the factory can add up to significant resource waste.
- According to industry data, the energy loss from 1 metre of uninsulated steam pipe would typically be equivalent to 3 tons of wasted coal annually.
- Regular inspections for leaks and faulty steam traps can have a large impact on the entire steam system.
- When combined with other measures such as pipe, valve, and flange insulation, the typical facility can save 1 to 4.3 percent of steam consumption with an investment of USD 5,000 to USD15,000 that will pay back in 2 to 7 months.



Steam Trap, source: TLV

# Common good practices

## Insulate equipment and tanks

- Proper insulation of dye tanks
- Utility lines, particularly steam
- Rollers in drying and stenter



Photo: Mohammad Abbas Uddin



# Common good practices

## Improve efficiency and consistency in bulk chemical preparation

- In most factories, workers carried bags of chemicals to the dyeing area and manually transferred chemicals to solution tanks, leading to waste of chemicals.
- We assumed a conservative estimate of 0.2 percent loss of chemicals (sodium sulfate, caustic soda, and soda ash) to spills.
- Bulk chemicals are best prepared in a solution that is pumped to dyeing machines as needed.
- Only required amounts of chemicals or prepared solutions should be taken to the production areas, with minimal surplus.



Copyright: Kazi Farhan Hossain Purba

# General good housekeeping basic/small measures

## Some bad practices

- Hoses left running
- Broken or missing valves
- Excessive water use in washing operations
- Leaks from pipes, valves, and pumps
- Cooling water or wash boxes left running when machinery is shut down
- Defective toilets and water coolers

# Common good practices

## Key takeaways

**In many cases from 10 to 30% of water consumption is attributed to the basic housekeeping and waste of good quality water in various processes.**

- Use domestic water flow restrictor to keep water flow at 5-7 liter/minute for washing and 9-12 liter/minute for showering;
- Installation of flow control devices and automatic stop valves on continuous machine;
- Installation of automatic controllers to accurately control of fill volume and liquor temperature;
- Substitution of overflow-flood rinsing method (in batch processes) by smart rinsing method;
- Optimization of scheduling in production;
- Water reuse / recycle whenever possible



# For further reading

- Water Efficiency in Textile Industry (WETI) in Pakistan
- International Water Stewardship Programme (IWaSP)
- Clean By Design: <https://www.nrdc.org/resources/green-textile-redux-clean-designs-10-best-practices-offer-even-greater-pollution-reduction>
- Reducing the Water Footprint of the Global Cotton-Textile Industry towards the UN Sustainable Development Goals. Final Report of the Joint Research Project InoCottonGROW, BMBFG Grant Number 02WGR1422A-M. FiW e.V., Aachen, Germany <https://www.inocottongrow.net/>
- Checklist based on best available techniques in the textile industry, Germany Federal Environment Agency (UBA) <https://www.umweltbundesamt.de/sites/default/files/medien/publikation/long/4294.pdf>
- Best Available Techniques (BAT) Reference Document for the Textiles Industry, European IPPC Bureau, [https://eippcb.jrc.ec.europa.eu/sites/default/files/2020-01/TXT\\_bref\\_D1\\_1.pdf](https://eippcb.jrc.ec.europa.eu/sites/default/files/2020-01/TXT_bref_D1_1.pdf)
- WWF Water Stewardship: [https://wwf.panda.org/our\\_work/water/water\\_management/](https://wwf.panda.org/our_work/water/water_management/)
- WWF, 2019. Transforming the textile sector's approach to water. [https://wwf.panda.org/our\\_work/water/?352012/Transforming-the-textile-sectorsapproach-to-water](https://wwf.panda.org/our_work/water/?352012/Transforming-the-textile-sectorsapproach-to-water)
- CEO Water Mandate Disclosure Guideline <https://ceowatermandate.org/disclosure/>
- Alliance for Water Stewardship <http://a4ws.org/about/>
- IFC Partnership of Cleaner Textiles <https://www.textilepact.net/>
- bluesign System – <https://www.bluesign.com/industry/bluesign-system/principles.html>

# Tools for water

- IFC Resource efficiency calculator <https://resourcesavingscalculator.textilepact.net/>
- WWF Water Risk Filter – <http://waterriskfilter.panda.org/>
- WRI Aqueduct Water Risk Filter <https://www.wri.org/>
- GEMI Local Water Tool <http://gemi.org/localwatertool/>
- Higg Index <https://apparelcoalition.org/the-higg-index/>
- Ceres Aqua Gauge <https://www.ceres.org/resources/tools/ceres-aqua-gauge-comprehensive-assessment-tool-evaluating-corporate-management>
- Water Evaluation and Planning Tool - <https://www.weap21.org/>
- WBCSD Global Water Tool <https://www.wbcd.org/Programs/Food-Land-Water/Water/Resources/Global-Water-Tool>
- Water Footprint Assessment <http://waterfootprint.org/en/water-footprint/corporate-water-stewardship/>
- Water Risk Monetizer <https://ceowatermandate.org/resources/water-risk-monetizer-2017/>
- WASH Sustainability Index Tool <http://washplus.org/rotary-usaid.html>
- Water Calculation Tool for the Wet Processing Sector <https://watercalculator.dnvgl.com/>
- BVE3 Environmental Emission Evaluator <https://staging.e3.bvonesource.com/cd/cpdHome>

**Deutsche Gesellschaft für  
Internationale Zusammenarbeit (GIZ) GmbH**

Registered offices  
Bonn and Eschborn

Friedrich-Ebert-Allee 32 + 36  
53113 Bonn, Germany  
T +49 228 44 60 - 0  
F +49 228 44 60 - 17 66

Dag-Hammarskjöld-Weg 1 - 5  
65760 Eschborn, Germany  
T +49 61 96 79 - 0  
F +49 61 96 79 - 11 15

E [info@giz.de](mailto:info@giz.de)  
I [www.giz.de](http://www.giz.de)